

# Tube Fitting Series Standard Type

unit:mm

## PGJ Reducer

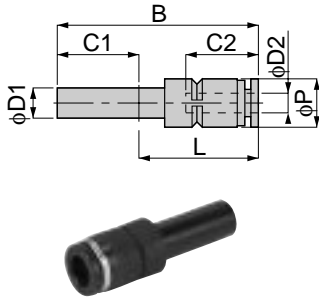

Model	Tube dia. φD1	Tube dia. φD2	B	L	φP	C1	C2	Mass (g)	Orifice (φmm)	Eff. a. (mm <sup>2</sup> )	
PGJ 6-4	6	4	41.5	24.5	10	17	15	3.5	4	5.3	
PGJ 8-4	8	4	44.5	26.5	12.5	18	15	5	6	5.3	
PGJ 8-6		6	45	27			17		5	9	
PGJ 10-6	10	6	47	27	14.5	20	17	7	5	9	
PGJ 10-8		8					18	7.5	7.5	20	
PGJ 12-6	12	6	54	30.5	17.5	23.5	17	9.5	9	9	
PGJ 12-8		8	54	30.5			18	10.5		9	20
PGJ 12-10		10	54.5	31			20	11.5		35	
PGJ 8-1/4	8	1/4	45	27	12.5	18	17	5	5	9	
PGJ 10-1/4	10	1/4	47	27	14.5	20	17	7	4	9	
PGJ 10-5/16		5/16					18	7.5	6	20	
PGJ 12-1/4	12	1/4	54	30.5	17.5	23.5	17	9.5	4	9	
PGJ 12-5/16		5/16	54	30.5			18	10.5	6	20	
PGJ 12-3/8		3/8	54.5	31			20	11.5	8	35	



## PU Union Straight

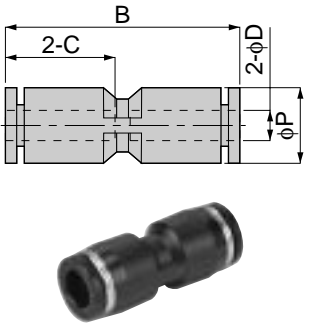

Model	Tube dia. φD	B	φP	C	Mass (g)	Orifice (φmm)	Eff. a. (mm <sup>2</sup> )
PU 4	4	31.5	10	15	5	3.8	5.3
PU 6	6	35.5	12.5	17	6.5	5.5	12.5
PU 8	8	38	14.5	18	9.5	7	20
PU 10	10	44	17.5	20	16	9	35
PU 12	12	48	21	23.5	22	11	59
PU 16	16	50	25	24.5	25	13	147.6
PU 1/4	1/4	35.5	12.5	17	6.5	5.5	12.5
PU 5/16	5/16	38.5	14.5	18	10	7	20
PU 3/8	3/8	44	17.5	20	16	9	35
PU 1/2	1/2	48	21	23.5	21	11	69.6
PU 5/8	5/8	50	25	24.5	25	13	147.6



## PG Different Diam. Union Straight

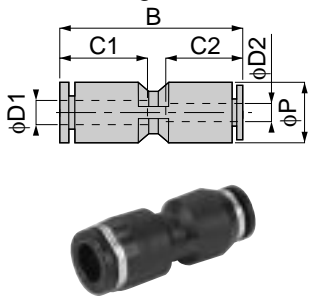

Model	Tube dia. φD1	Tube dia. φD2	B	φP	C1	C2	Mass (g)	Orifice (φmm)	Eff. a. (mm <sup>2</sup> )
PG 6-4	6	4	34.5	12.5	17	15	6.5	3	5.3
PG 8-6	8	6	38.5	14.5	18	17	9	5.5	12.5
PG 10-8	10	8	43.5	17.5	20	18	14.5	7	20
PG 12-10	12	10	48	21	23.5	20	22.5	9	35
PG 12-3/8		3/8							
PG 16-12	16	12	50	25	24.5	23.5	26.5	10	88.6
PG 1/4-4	1/4	4	34.5	12.5	17	15	6.5	3	5.3
PG 5/16-1/4	5/16	1/4	38.5	14.5	18	17	9	3	12.5
PG 3/8-5/16	3/8	5/16	43.5	17.5	20	18	15	5.5	20
PG 1/2-3/8	1/2	3/8	48	21.5	23.5	21.5	20.5	9	50.8
PG 5/8-1/2	5/8	1/2	50	25	24.5	23.5	26	10	90.6

